

Fireball® Supervised Hearing Impaired Strobe Warning Light

Model FB24STHI



LIGHT DUTY STROBE LIGHT

- Available in 24VDC
- Four wires and supervisory diode
- Clear dome
- 10,000 hour strobe tube
- Integrated 1/2 - inch pipe mount and surface mount
- Type 4X, IP66 enclosure
- In-rush protected
- UL1971 Listed
- UL Listed and CSFM Approved

Federal Signal's brightest and most compact strobe light, this supervised FireBall® emits a powerful "lightning bolt" flash of light. Approximately five inches tall and four inches in diameter and rated at 300 effective candela, the FB24STHI is economical and effective. The Fireball is available in 24VDC, this model is UL Listed and CSFM Approved.

The FB24PSTHI features a voltage in-rush limiting PCB design that provides greater compatibility with control systems and panels and less electrical interference with in-rush sensitive devices.

The FB24STHI features a clear dome that twists off easily for quick dome and lamp replacements. The newly redesigned base features an integrated 1/2" pipe mount boss as well as the three holes required for surface mount configurations. Black epoxy paint is electrostatically applied to the base for superior corrosion resistance. The Fireball dome and base design provides a watertight, dust-tight and corrosion resistant Type 4X rating.

The Fireball FB24STHI contains a supervisory diode and four wire leads, for use in fire alarm applications. This strobe is UL 1971 listed, for hearing impaired applications.

Model	Voltage	Operating Current	Flash Rate/Minute	Candela Peak ¹	ECP ²	Mount
FB24STHI	24VDC	0.7 amps (2.0 amp, in-rush)	80	1,000,000	300	1/2" Pipe/Surface

¹ Peak candela is the maximum light intensity generated by a flashing light during its light pulse

² ECP (Effective Candela) is the intensity that would appear to an observer if the light were burning steadily



FIREBALL® STROBE WARNING LIGHT (FB24STHI)

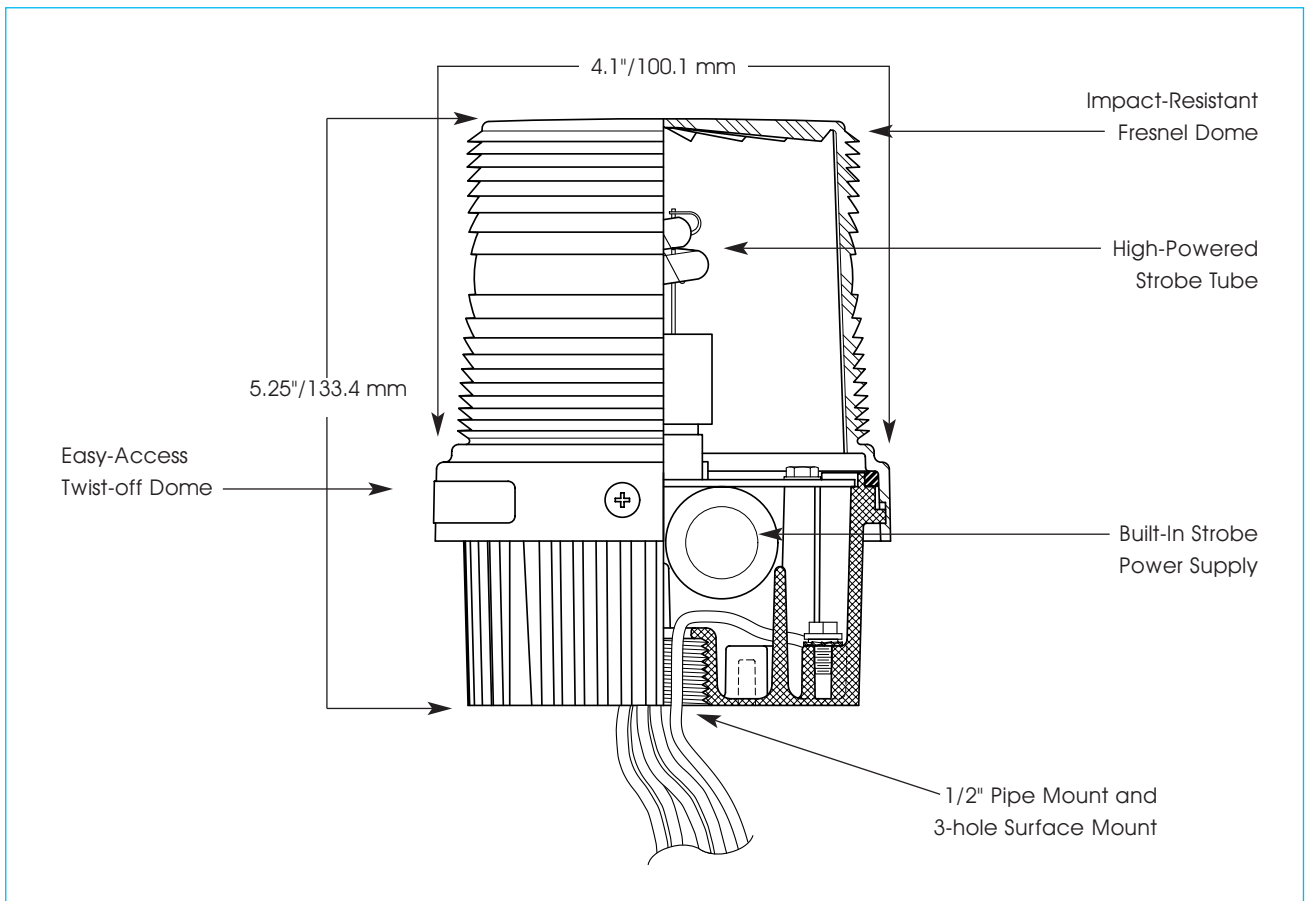

SPECIFICATIONS

Lamp Life*:	10,000 Hours	10,000 Hours
Lamp Style:	Strobe	Strobe
Operating Temperature:	-31°F to 150°F	-35°C to 66°C
Net Weight:	1.45 lbs.	0.7 kg
Shipping Weight:	1.7 lbs.	0.8 kg
Height:	5.25"	133.4 mm
Diameter:	4.1"	100.1 mm

* Optimal hours under ideal conditions.

HOW TO ORDER

- Specify model, voltage and color
- Specify options:
Corner Bracket (LCMB2)*
Wall Bracket (LWMB2)*
- Please refer to Model Number Index FS24STHI beginning on page 381

* Brackets not Type 4X rated.

REPLACEMENT PARTS

<u>Description</u>	<u>Part Number</u>
PC Assembly, 24VDC	K2001202C
Dome, Clear	K8550320A-02
Strobe Tube	K8107177A